

## Ring Cell

### Description

The Cavity Eye improved pressure sensors are developed for cavity pressure measuring. The sensors are water and shock resistant, and available with 2 different type of geometry (15 and 26 mm), which have a maximum load range from 300 N to 40 kN, with normal and high temperature range.

Cavity Eye uses only indirect sensors. From our experiences, the indirect measurement is much more precise, than the direct measurement. Using indirect measurement results in no need for sensor maintenance during the whole lifetime of the mould. Thanks to the improved sensor geometry the manufacturing of the sensor pocket is simpler, and the sensor installation is easier than ever!

### Application

The sensors offered by Cavity Eye were developed for cavity pressure measurement in injection moulds.

Fulfilling the industry's requirements, the sensors are designed heavy-duty, with water and shock resistance, thus applicable for industrial pressure measuring.

### How does it work

The pressure sensor's emitted signals – caused by the excitation – are directly proportional to the force acting on the sensor's measuring pin. Knowing the area of the measuring ejector pin's surface in the cavity, whereat the cavity pressure is acting on, the pressure inside the cavity can be calculated.

## Data Sheet

RC15

RC26



### Technical Data

#### RC15

Weight		
RC15-03-...	g	10
RC15-1-...	g	15
RC15-5-...	g	21
Diameter without ring	mm	15
Diameter with ring	mm	16
Height	mm	8
Hardness		
RC15-04-...	HB	95
RC15-1-..., RC15-5-..	HRC	45
Operating temperature range		
RC ...	°C	-40 - +150
RC ... -HT	°C	-40 - +200
Excitation voltage	V	5
Protection rating	IEC 60529:1989	IP67
Maximum load		
RC15-1-...	kN	1
RC15-5-...	kN	5
Wire color codes		
GND		Black
Excitation		Red
Differential signal +		White
Differential signal -		Yellow
Wire cross section		
RC ...	AWG	30
RC ... -HT	AWG	26
Wire length	m	1,5
Linearity deviation	%	<1
Bend at max. load	mm	<0,06

## RC26

Weight		
RC26-20-...	g	33
RC26-40-...	g	41
Diameter without ring	mm	26
Diameter with ring	mm	27,5
Height	mm	12
Hardness	HRC	45
Operating temperature range		
RC ...	°C	-40 - +150
RC ... -HT	°C	-40 - +200
Excitation voltage	V	5
Protection rating	IEC 60529:1989	IP67
Maximum load		
RC26-20-...	kN	20
RC26-40-...	kN	40
Wire color codes		
GND		Black
Excitation		Red
Differential signal +		White
Differential signal -		Yellow
Wire cross section		
RC ...	AWG	30
RC ... -HT	AWG	26
Wire length	m	1,5
Linearity deviation	%	<1
Bend at max. load	mm	<0,06

## Types

Our sensors available in 2 different diameters (15 mm and 26 mm), and 5 different maximum loads (300 N and 1, 5, 20, 40 kN). The normal temperature sensors can be used up to 150°C environment. In case of moulds tempered on higher temperature, there is a High Temperature Sensor, which can be used up to 200°C.

## Item number information

RC  -  -

Diameter	
15 mm/16 mm	15
26 mm/27,5 mm	26
Max. load	
300 N	03
1 kN	1
5 kN	5
20 kN	20
40 kN	40
Max. temperature	
150°C	-
200°C	HT

## Dimensions

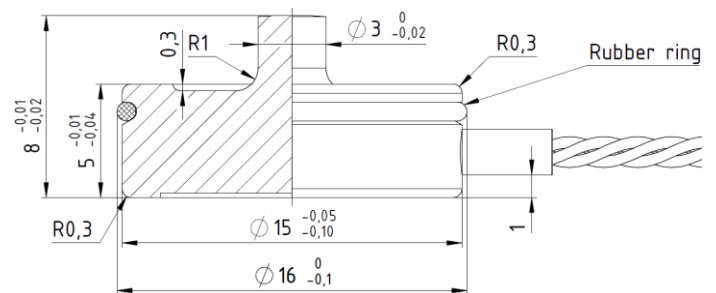

1. Figure: RC15 Sensor

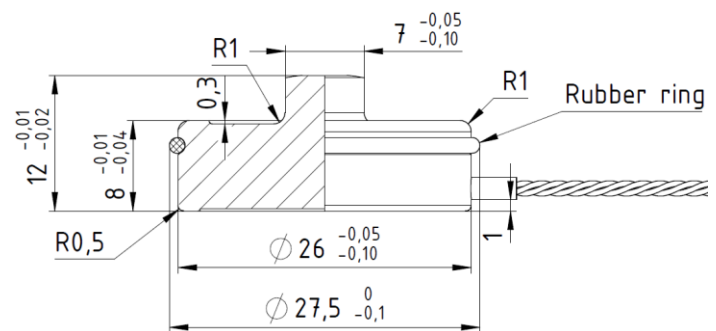

2. Figure: RC26 Sensor

## Installation

Our sensors are used for indirect pressure measurement in all instances, with the help of a transfer pin. The sensors can be placed both in the fixed and the moving side of the mould. The sensors are installed in the moving side clamping plate in 90% of all cases, in line with the ejector pin's axis. The measuring surface of the sensor connects to the ejector pin indirectly through a transfer pin. If there is no option for transfer pin, then a static pin is used. Thereby almost every injection mould can be prepared for using the Cavity Eye system.

There are 2 types of installing option for the Cavity Eye sensors. The first called front installation, where the sensor pockets are machined from the direction of the parting line of the mould. The sensor pockets design and dimensions can be seen in the 3. figure in case of RC15 sensor.

In case of rear installation, the plate is machined from the clamping unit's side. The sensor pockets design and dimensions can be seen in the 4. figure in case of RC15 sensor.

The new sensor with rubber ring, allows a bigger fillet at the bottom of the sensor pocket, and bigger tolerance at the pocket diameter compared to the previous generation sensor, which makes the manufacturing easier and helps reducing the machining cost.

## Optional accessories

Name	Item number
Front plate RC15	PC15-FP
Back plate RC15	PC15-BP
Front plate RC26	PC26-FP
Back plate RC26	PC26-BP
M4×10 screw (DIN 7991)	M4-10

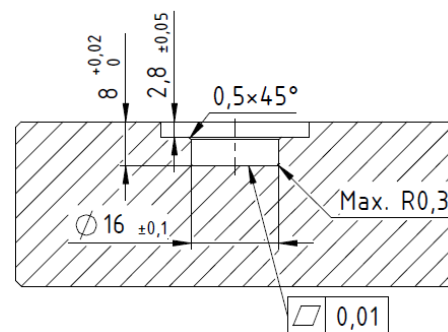
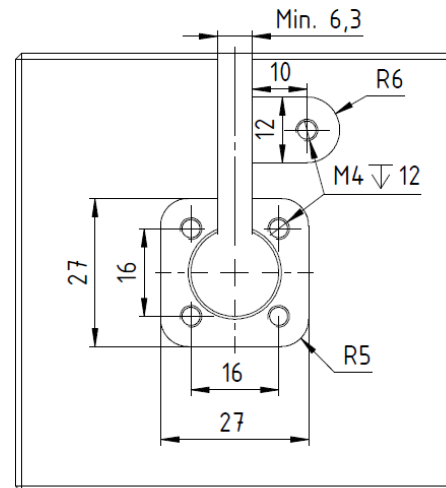

3. Figure: RC15 front installation

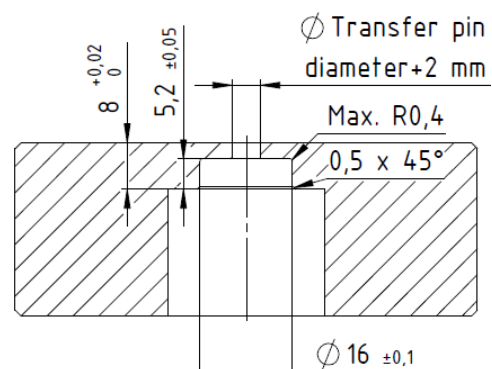
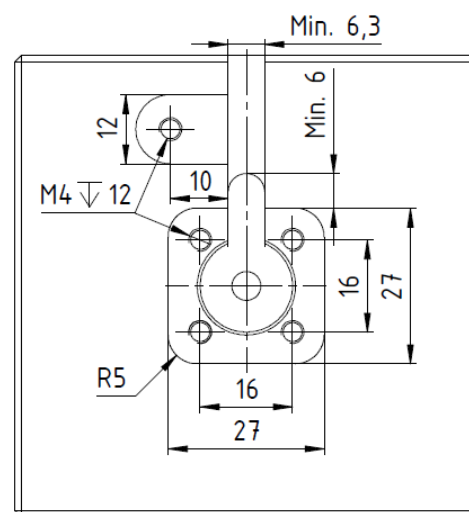

4. Figure: RC15 rear installation